

IMPORTANT INFORMATION

- Lay the playset on a flat surface.
- Keep long hair and other loose objects, like shoelaces, away from the rotating tires of the vehicles.
- DO NOT launch vehicles at people or pets. Avoid obstacles, as they could become damaged from vehicle impact.
- Do not play with cars in the street or where there is vehicular traffic or in heavily traveled areas with pedestrians.
- Do not stand on, sit on or throw cars as doing so can result in injury to the person and irreparable damage to the units.
- Avoid driving the cars through water, mud, etc.
- If not using the playset, it is recommended to drive the cars on hard, flat surface in an open area and away from obstacles.
- Batteries not required.

LIMITED WARRANTY

The Little Tikes Company makes fun, high quality toys. We warrant to the original purchaser that this product is free of defects in materials or workmanship for one year * from the date of purchase (dated sales receipt is required for proof of purchase). At the sole election of The Little Tikes Company, the only remedies available under this warranty will be the replacement of the defective part or replacement of the product. This warranty is valid only if the product has been assembled and maintained per the instructions. This warranty does not cover abuse, accident, cosmetic issues such as fading or scratches from normal wear, or any other cause not arising from defects in material and workmanship. *The warranty period is three (3) months for daycare or commercial purchasers.

U.S.A. and Canada: For warranty service or replacement part information, please visit our website at www.littletikes.com, call 1-800-321-0183 or write to: Consumer Service, The Little Tikes Company, 2180 Barlow Road, Hudson OH 44236, U.S.A. Some replacement parts may be available for purchase after warranty expires—contact us for details.

Outside U.S.A. and Canada: Contact place of purchase for warranty service. This warranty gives you specific legal rights, and you may also have other rights, which vary from country/state to country/state. Some countries/states do not allow the exclusion or limitation of incidental or consequential damages, so the above limitation or exclusion may not apply to you.



3-in-1 Rollin' Bowlin' Racin' Playset

AGES 3+ YEARS

ADULT SUPERVISION REQUIRED

SKU: 660672

CONTENTS

- A. 2 Vehicles B. 1 Launcher C. 5 Bowling Pins D. Playset (Packaging Box)

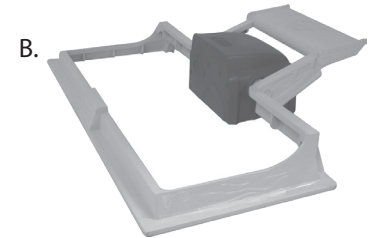

Please keep this manual as it contains important information.



© The Little Tikes Company, an MGA Entertainment company. LITTLE TIKES® is a trademark of Little Tikes in the U.S. and other countries. All logos, names, characters, likenesses, images, slogans, and packaging appearance are the property of Little Tikes.

Printed in China
0821-0-EINT

Little Tikes Consumer Service
2180 Barlow Road,
Hudson, Ohio 44236 U.S.A.
1-800-321-0183

MGA Entertainment UK Ltd.
50 Presley Way, Crownhill, Milton
Keynes, MK8 0ES, Bucks, UK
support@LittleTikesStore.co.uk
Tel: +0 800 521 558

MGA Entertainment (Netherlands) B.V.
Baronie 68-70, 2404 XG Alphen a/d Rijn,
The Netherlands
Tel: +31 (0) 172 758038

Imported by MGA Entertainment Australia Pty Ltd
Suite 2.02, 32 Delhi Road
Macquarie Park NSW 2113
1300 059 676



www.littletikes.com
www.littletikes.co.uk
www.littletikes.com.au

Illustrations are for reference only. Styles may vary from actual contents.

Please remove all packaging including tags, ties & tacking stitches before giving this product to a child.

SET THE PLAYSET

Packaging turns into playset!

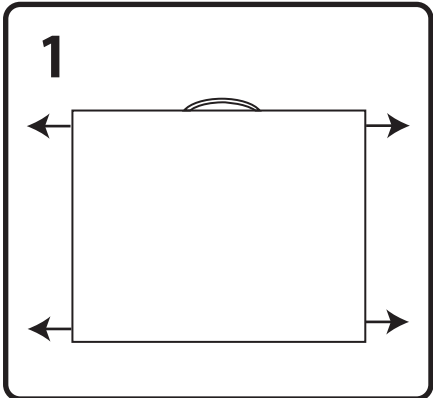

Unhook the hook and loop fasteners from each corner of the box. Then, lift up the side panels.

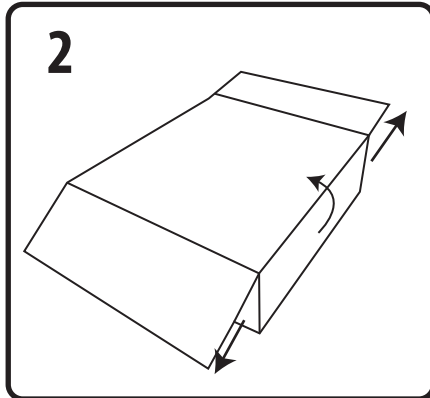

Unhook the hook and loop fasteners from the front corners of the box and open the box.

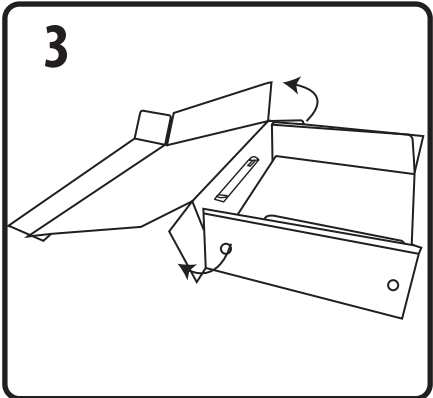

Unhook the last two hook and loop fasteners and lay down the top part of the box.

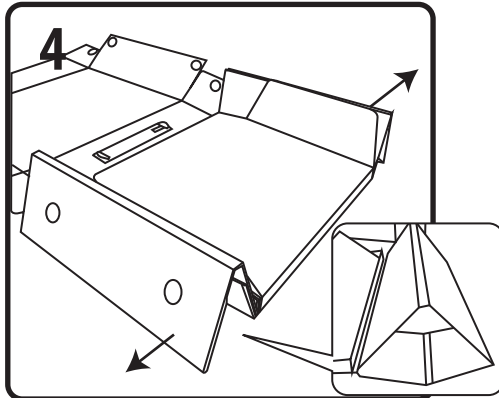

Carefully pull out the sides to extend the stages.

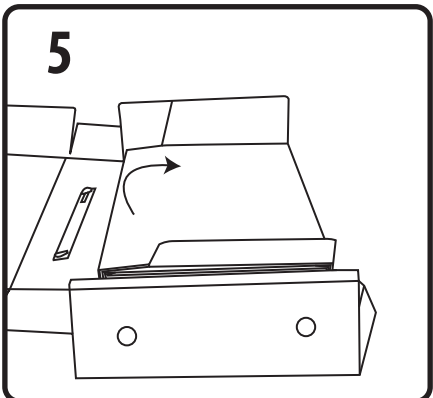

Lift up and continue unfolding the lane.

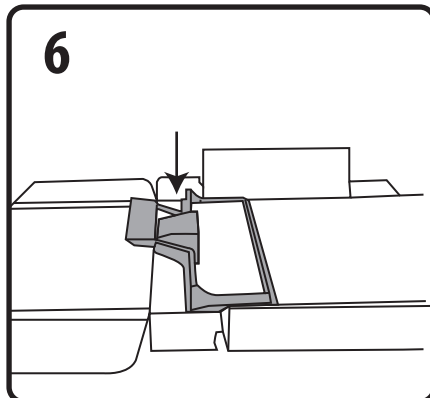

Place the launcher on top of the handle located inside the box.

TIME TO PLAY!

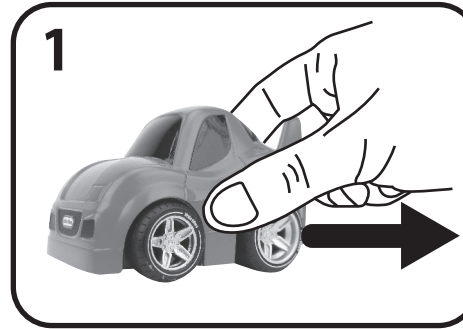

Pull the vehicle back until you hear one or two clicks.

IMPORTANT NOTE: Do not continue pulling after you hear one or two clicks.

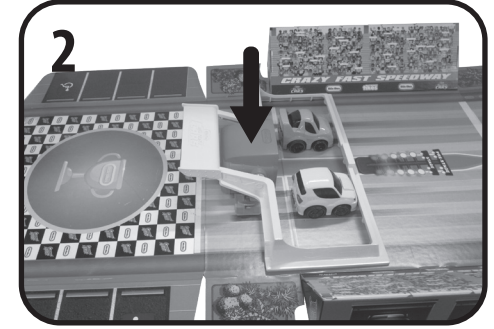

Hold the back wheels of the vehicle and lift it to place inside the launcher.

IMPORTANT NOTE: Hold down the center of the launcher so it stays in place after inserting the cars.

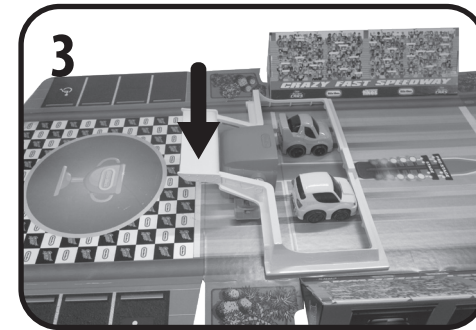

Push down the launcher to release the vehicles.

3 WAYS TO PLAY!

Car Bowling:

1. Place the bowling pins on top of the circles at the end of the lane. (Fig. 1)
2. Pull back one vehicle to wind it up and then place it inside the launcher.
3. Push down the launcher to release the vehicle and knock down the pins. Keep track of your score.
4. Then the next player goes.

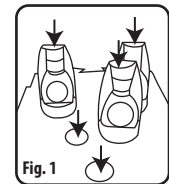

Fig. 1

Drag Racing:

1. Pull back the vehicles to wind them up and then place them inside the launcher.
2. Push down the launcher to release the vehicles.
3. First one to the finish line is the winner.

Shuffle Board:

To play Shuffle Board, first decide on a winning number and the winner is the person who reaches that number first. Players will go one at a time.

1. Pull back the vehicle to wind it up and then place it inside the launcher.
2. Push down the launcher to release the vehicle. The goal is to try to get the vehicles into the areas with numbers on the lane. (Fig. 2)
3. If the vehicle lands in the hazard area, you don't get any points. If the vehicle lands in the green area, you will either win 1 point or 500 points depending on which side the car lands on. If the vehicle lands on the yellow, you will either win 2 or 250 points. If the vehicle lands on the red, you will either win 3 or 100 points. Keep track of your score.

NOTE: There is a learning curve. Wind up the cars just enough to reach the desired area on the board.

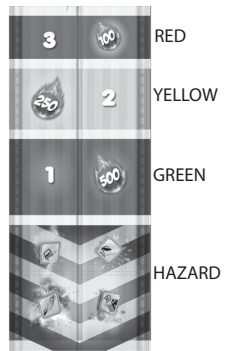

Fig. 2