

Place the Wheel (L) between the two Leg Supports (B1, B2).

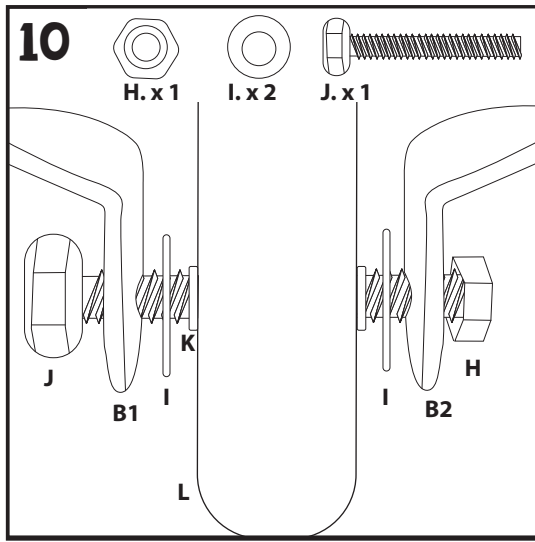

Insert one Bolt (J) through the Left Leg Support (B1). Then, place one Large Washer (I) over the bolt. Slide the Bolt through the Bushing (K) in the Center of the Wheel (L). Slide another Large Washer (I) over the Bolt. Place the end of the Bolt through the Right Leg Support (B2). Hold the Bolt with one wrench, and secure the assembly with the Large Nut (H) using another wrench.

LIMITED WARRANTY

The Little Tikes Company makes fun, high quality toys. We warrant to the original purchaser that this product is free of defects in materials or workmanship for one year * from the date of purchase (dated sales receipt is required for proof of purchase). At the sole election of The Little Tikes Company, the only remedies available under this warranty will be the replacement of the defective part or replacement of the product. This warranty is valid only if the product has been assembled and maintained per the instructions. This warranty does not cover abuse, accident, cosmetic issues such as fading or scratches from normal wear, or any other cause not arising from defects in material and workmanship. *The warranty period is three (3) months for daycare or commercial purchasers. U.S.A and Canada: For warranty service or replacement part information, please visit our website at www.littletikes.com, call 1-800-321-0183 or write to: Consumer Service, The Little Tikes Company, 2180 Barlow Road, Hudson OH 44236, U.S.A. Some replacement parts may be available for purchase after warranty expires—contact us for details. Outside U.S.A and Canada: Contact place of purchase for warranty service. This warranty gives you specific legal rights, and you may also have other rights, which vary from country/state to country/state. Some countries/states do not allow the exclusion or limitation of incidental or consequential damages, so the above limitation or exclusion may not apply to you.

Please keep this manual as it contains important information.



© The Little Tikes Company, an MGA Entertainment company. LITTLE TIKES® is a trademark of Little Tikes in the U.S. and other countries. All logos, names, characters, likenesses, images, slogans, and packaging appearance are the property of Little Tikes.

Printed in China • 1020-0-E/INT

Little Tikes Consumer Service
2180 Barlow Road
Hudson, Ohio 44236 U.S.A.
1-800-321-0183

MGA Entertainment UK Ltd.
50 Presley Way, Crownhill, Milton
Keynes, MK8 0ES, Bucks, UK
support@LittleTikesStore.co.uk
Tel: +0 800 521 558

MGA Entertainment (Netherlands) B.V.
Baronie 68-70, 2404 XG Alphen a/d Rijn,
The Netherlands
Tel: +31 (0) 172 758038
Email: klantenservice@mgaee.com

**Imported by MGA Entertainment
Australia Pty Ltd**
Suite 2.02, 32 Delhi Road
Macquarie Park NSW 2113
1300 059 676



GROWING
GARDEN™

Wheelbarrow & Shovel

3+
YEARS

SKU: 656477

ADULT ASSEMBLY AND SUPERVISION REQUIRED

CONTENTS

NOTE: Extra hardware included.

- | | | |
|-------------------------|--------------------|--------------------|
| A. 1 Wheelbarrow | D. 9 Small Nut | I. 2 Large Washers |
| B1. 1 Left Support Leg | E. 3 Small Screw | J. 1 Large Bolt |
| B2. 1 Right Support Leg | F. 3 Small Washers | K. 1 Bushing |
| C. 2 Handles | G. 6 Large Screws | L. 1 Wheel |
| | H. 1 Large Nut | M. 1 Shovel |

REQUIRED TOOLS FOR ASSEMBLY (NOT INCLUDED)

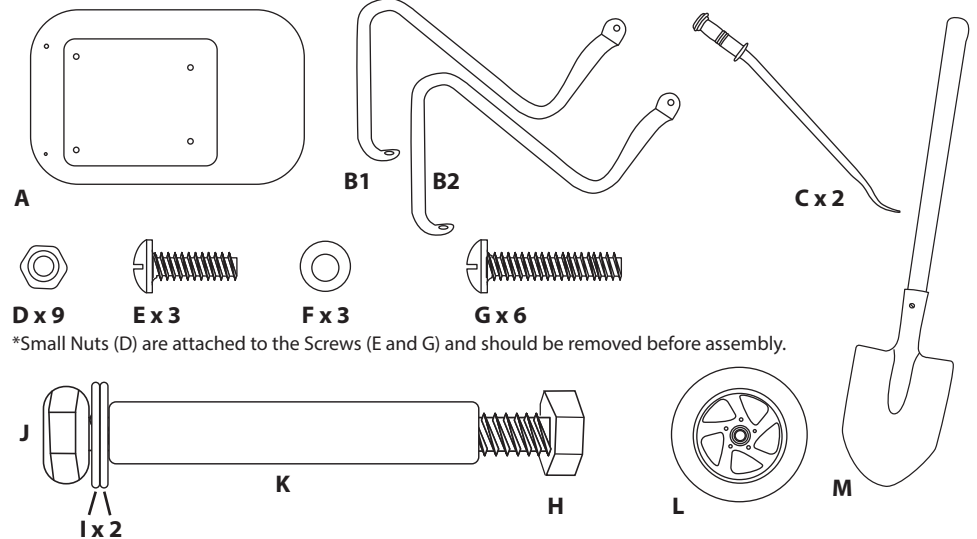

Illustrations are for reference only. Styles may vary from actual contents.
Please remove all packaging including tags, ties & tacking stitches before giving this product to a child.

⚠ WARNING

- ADULT ASSEMBLY REQUIRED.
- ADULT SUPERVISION REQUIRED.
- Prior to assembly, this package contains small parts: hardware which is a choking hazard and may contain sharp edges and sharp points. Keep away from children until assembled.
- An adult must assemble and check this product before use to minimize risk of the unit tipping or falling.
- Check inserted and threaded connections regularly, and tighten hardware as needed.

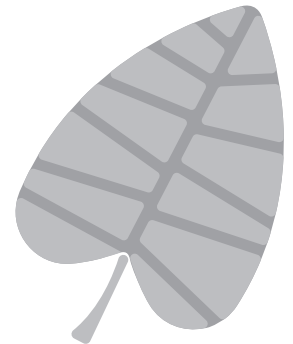

ASSEMBLY

Use a wrench (not included) to hold the nuts in place while using a screwdriver (not included) to tighten the screws.

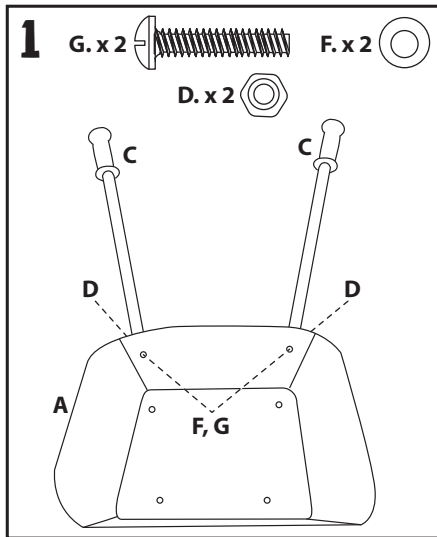

Align the Handles (C) with the openings on the back of the Wheelbarrow (A). Slide a Small Washer (F) onto both Large Screws (G). Insert the screws into the openings on the inside of the wheelbarrow and through the openings on the Handles (C). Secure the screws on the backside of the Handles using two Small Nuts (D).

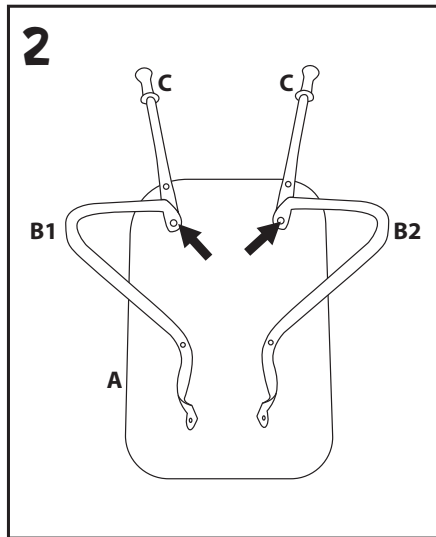

Position the Left Support Leg (B1) and Right Support Leg (B2) under the Wheelbarrow (A) so that the openings align with the lower openings on the handles (C). The legs should bow outward.

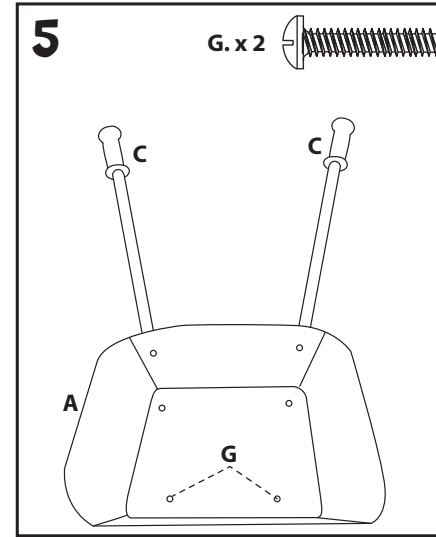

Insert two Large Screws (G) into the openings on the inside of the Wheelbarrow and through the openings on the Leg Supports (B1, B2).

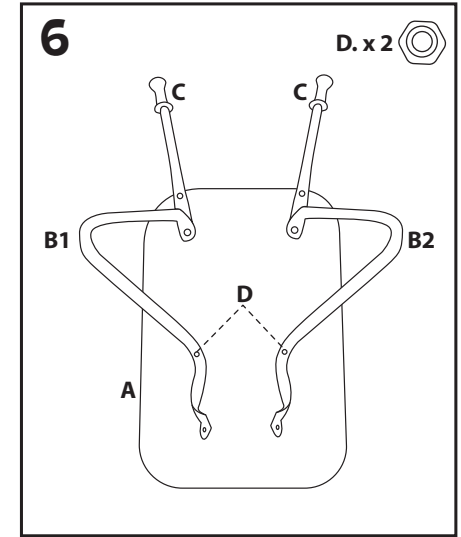

Secure the Large Screws (G) on the underside of the Wheelbarrow using two Small Nuts (D).

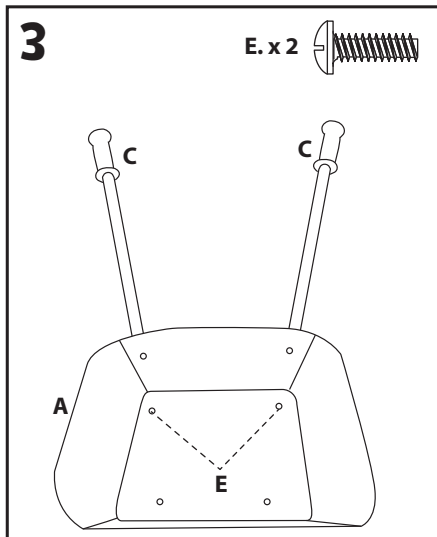

Insert two Small Screws (E) into the openings on the inside of the Wheelbarrow and through the openings on the Leg Supports (B1, B2) and Handles (C).

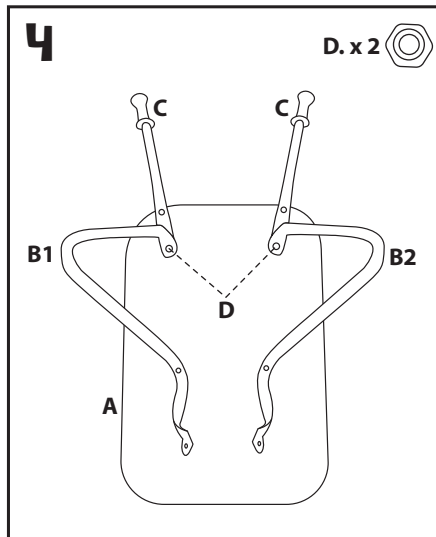

Secure the Small Screws (E) on the underside of the Wheelbarrow using two Small Nuts (D).

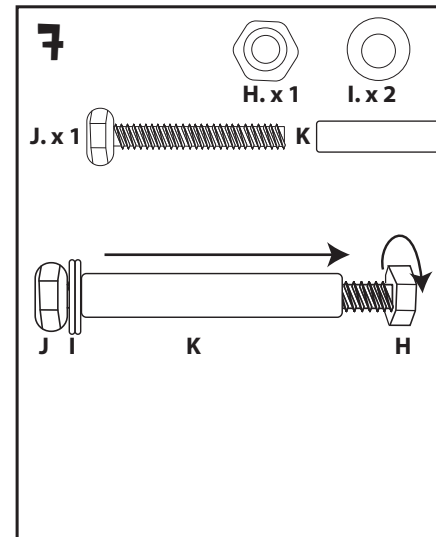

Remove the Large Nut (H), Bushing (K), and two Large Washers (I) from the Large Bolt (J).

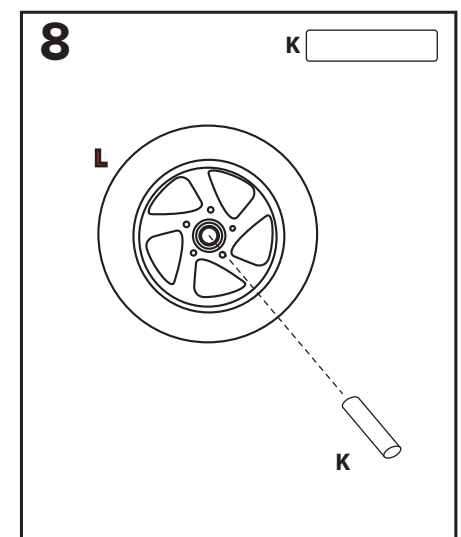

Insert the Bushing (K) in to the center opening of the wheel.

