

# 613692

## Slam & Curve Slide Water Park Instructions for Installation and Operation

Ages: 5-10 years

**CAUTION - ELECTRICALLY OPERATED PRODUCT.**  
OPERATION OF BLOWER FAN UNIT NOT RECOMMENDED FOR CHILDREN UNDER 14 YEARS OF AGE.  
AS WITH ALL ELECTRIC PRODUCTS, PRECAUTIONS SHOULD BE OBSERVED DURING HANDLING AND  
USE TO PREVENT ELECTRIC SHOCK.

**⚠ WARNING: FAILURE TO FOLLOW THESE INSTRUCTIONS COULD RESULT IN SERIOUS INJURY OR DEATH.**  
Do not use extension cords with this product. Outdoor use only. Retain instructions with product.

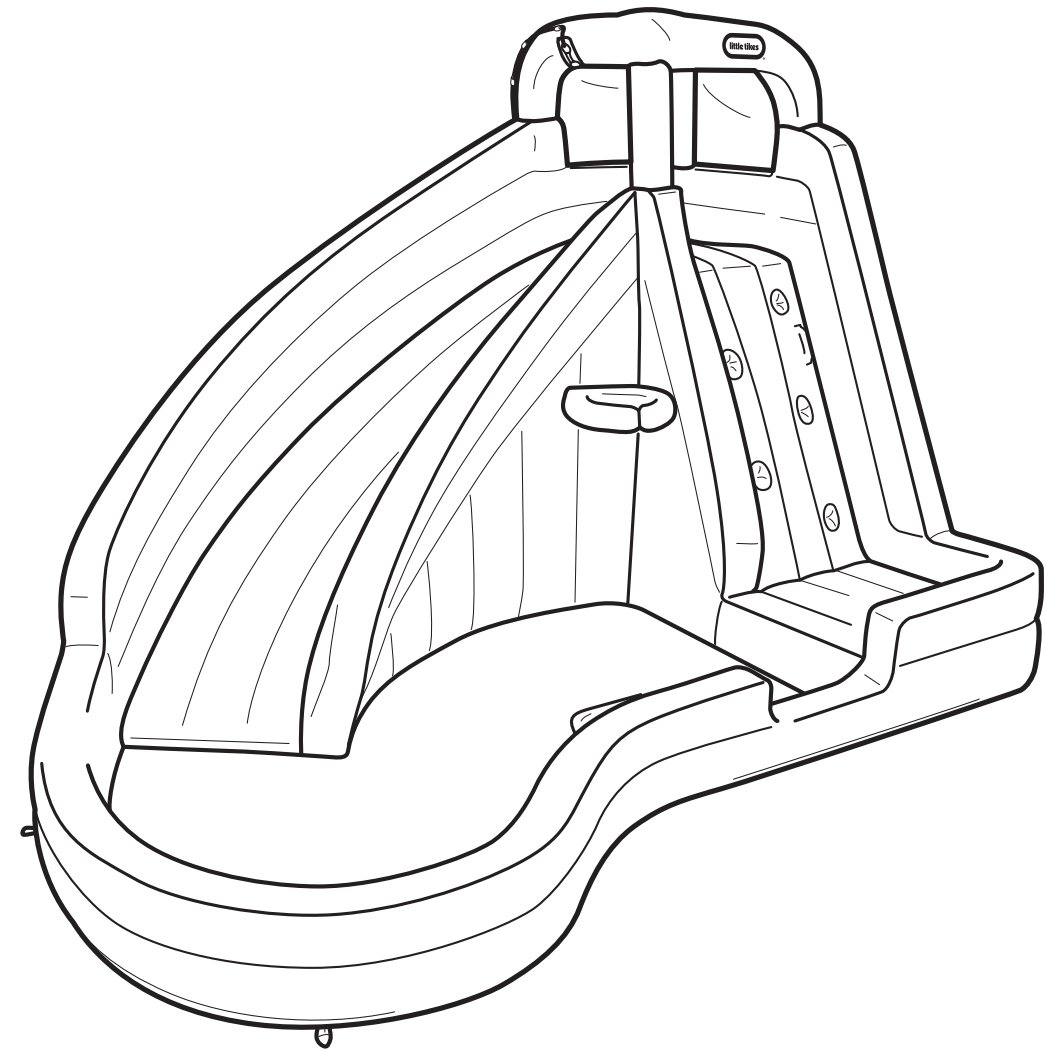

'Let's care for the environment!'  
The wheelie bin symbol indicates that the product must not be disposed of with other household waste. Please use designated collection points or recycling facilities when disposing of the item

Please keep this manual as it contains important information.

**little tikes®**

**MGA**  
ENTERTAINMENT®

TM & © The Little Tikes Company,  
an MGA Entertainment company.  
LITTLE TIKES™ and all related logos, names,  
characters, distinctive likenesses and slogans,  
as well as the packaging and images appearing  
thereon, are the exclusive property of The Little Tikes Company.  
Little Tikes Consumer Services  
2180 Barlow Road  
Hudson, Ohio 44236 USA  
(800) 321-0183  
**Printed in China**

1108-0-E

[www.littletikes.com](http://www.littletikes.com)

**MGA**  
ENTERTAINMENT®

**little tikes®**

**ATTENTION: Please DO NOT return to the store.**  
**If you encounter problems, or have questions, please call our qualified customer service technicians at 1-800-321-0183.**

## Storage

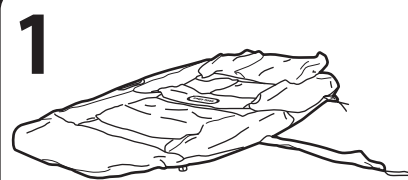

**1**  
 Fold all pieces of the Water Park (i.e. Slide, Air Inlet Tube, etc.) toward the center. NOTE: If bottom surface is still moist, allow it to air dry prior to folding.

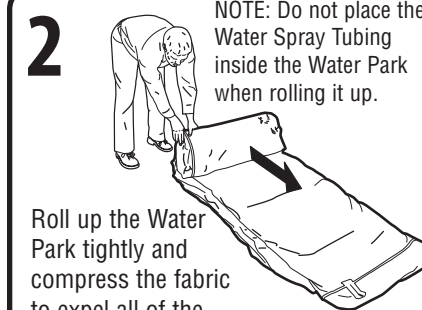

**2**  
 Roll up the Water Park tightly and compress the fabric to expel all of the remaining air. NOTE: Do not place the Water Spray Tubing inside the Water Park when rolling it up.

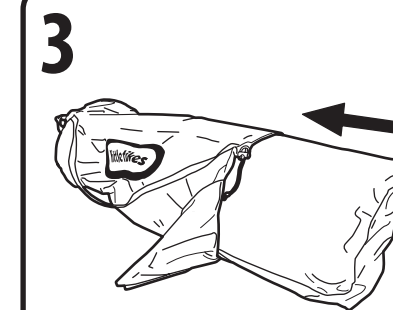

**3**

## Repair Kit Instructions

**WARNING: NOT A TOY. ADULT USE ONLY.**  
 Repair kit. Keep away from children

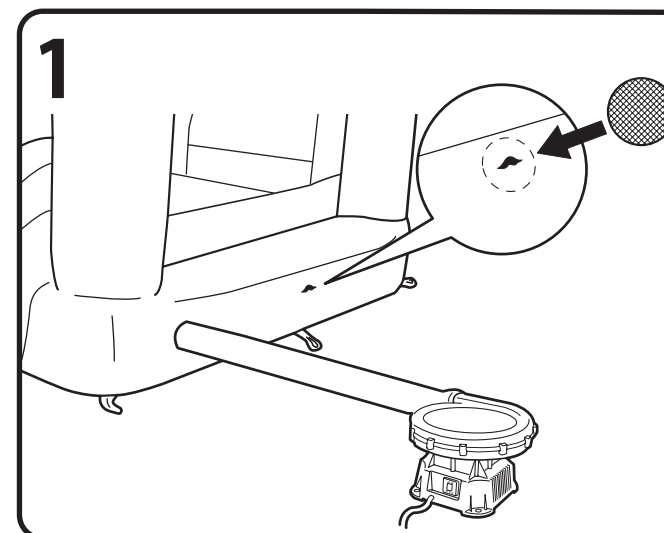

**1**

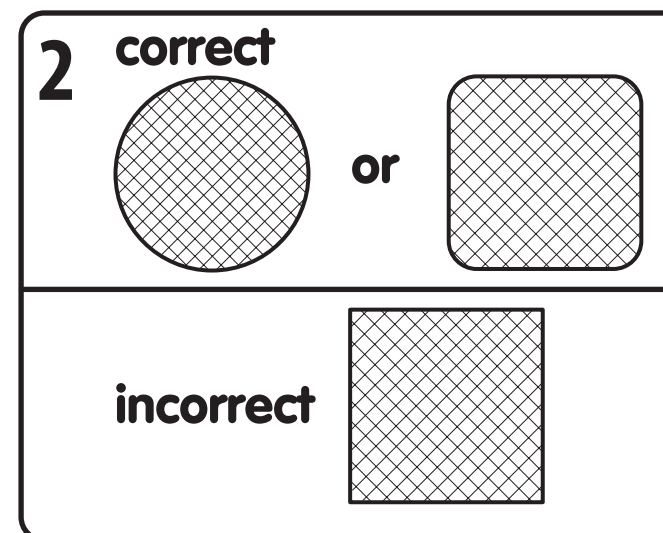

**2**

**correct**

or

**incorrect**

**WARNING:** Repair patches must be applied by an adult only. KEEP OUT OF REACH OF CHILDREN.

### REPAIR PATCH INSTRUCTION

1. Deflate the item, clean the damaged area and allow it to dry thoroughly.
2. Cut a portion of the patch allowing to the size needed and round the corners. (See Fig. 1 & 2).
3. Remove the adhesive backing from the patch material, position the patch over the damaged area and smooth out any bubbles.
4. Allow to sit for 30 minutes before re-inflating.

## Maintenance & Disposal

- As an outdoor product, the inflatable is subject to wear and deterioration. Inspect for signs of fabric failure; weak or torn surfaces must be repaired promptly.
- Product should never be stored wet. Allow to dry before rolling up.
- Surface washable only.
- Disassemble and dispose of the equipment in a safe manner so as not to produce hazardous conditions.
- Blower should be returned to collection center capable of processing electrical / electronic waste.

# Draining & Deflation

**IMPORTANT** - Inflatable Water Park MUST be drained of all water and be COMPLETELY DRY before storage in order to avoid mold and mildew. DO NOT fold and store Water Park if any moisture remains.  
**IMPORTANT** - All children MUST EXIT the Water Park before deflation or draining water.  
**IMPORTANT** - For best results, 2-4 people should drain and move the Water Park.

**1**

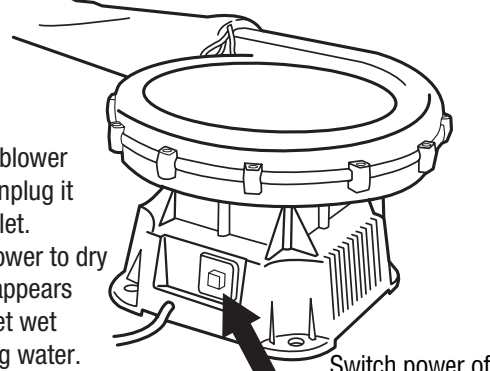

Turn off the blower motor and unplug it from the outlet. Move the blower to dry ground if it appears that it will get wet from draining water.

Switch power off

**2**

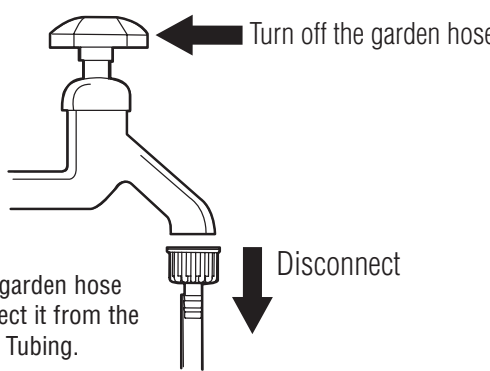

Turn off the garden hose and disconnect it from the Clear Plastic Tubing.

Turn off the garden hose  
Disconnect

**3**

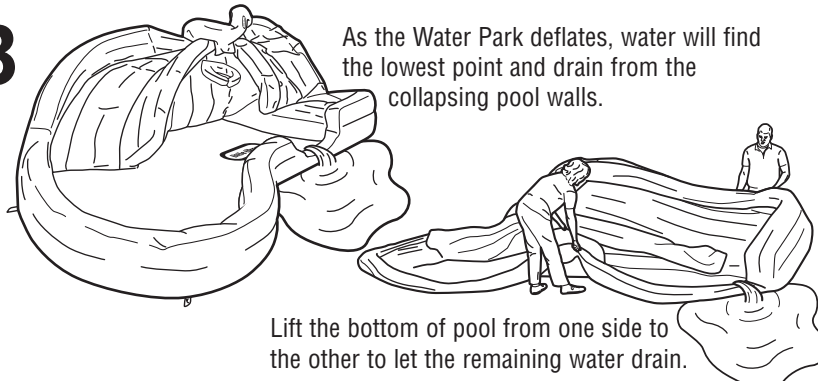

As the Water Park deflates, water will find the lowest point and drain from the collapsing pool walls.

Lift the bottom of pool from one side to the other to let the remaining water drain.

**4**



Remove stakes and drag the Water Park away from the drained water to a dry area.

**5**

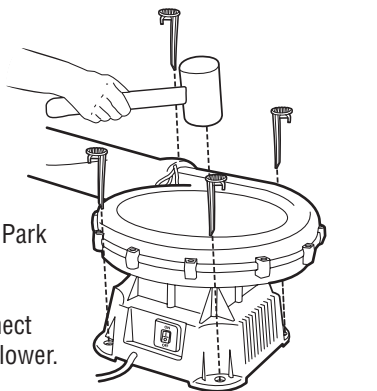

Re-stake the Water Park and blower, tie the Inflation tube to the blower, then reconnect and power up the blower.

Leave the Water Park inflated until all remaining water has evaporated and the Water Park is dry. This may take 2 hours or more depending on weather conditions.

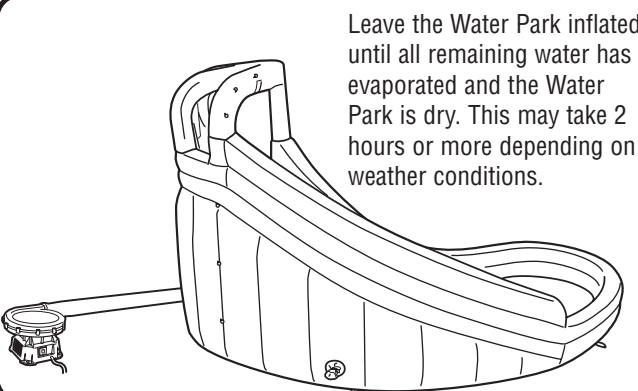

**7**

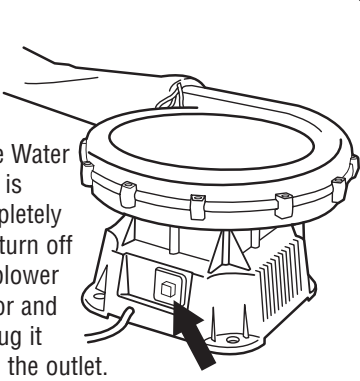

Once Water Park is completely dry, turn off the blower motor and unplug it from the outlet.

**8**

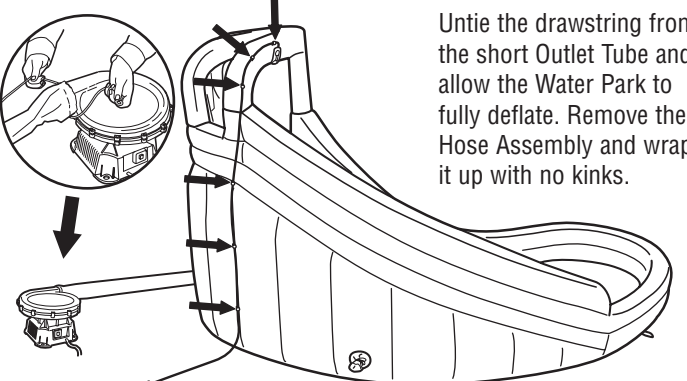

Remove and drain the Hose Assembly from the Water Park.

Untie the drawstring from the short Outlet Tube and allow the Water Park to fully deflate. Remove the Hose Assembly and wrap it up with no kinks.

9

# Contents

- A 1 inflatable water park
- B 5 water park stakes
- C 1 storage bag
- D 1 heavy-duty blower
- E 4 blower stakes
- F 1 hose assembly kit
- G 1 water anchor bag
- H 1 repair kit
- I 1 inflatable basketball

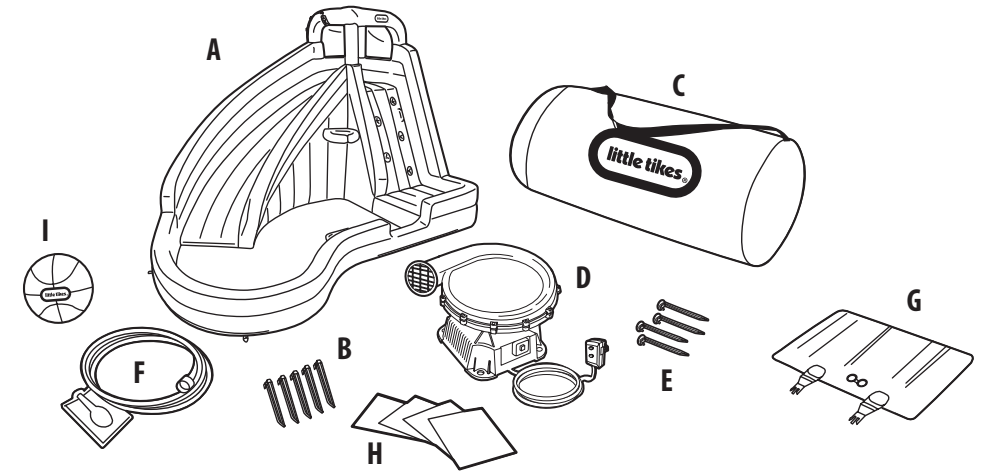

## ⚠ SAFETY WARNINGS: ELECTRICAL

Keep this information for future reference.

**UL** LISTED 3FW2 E234531  
**MODEL FJ-28**  
**BLOWER SPECIFICATIONS: 120V (AC), 60 Hz, 3.5 A, 420W**

**DANGER** ⚠ CAUTION: ELECTRICALLY OPERATED PRODUCT

- ⚠ DANGER - TO PREVENT ELECTRIC SHOCK, DO NOT IMMERSE IN WATER. WIPE CLEAN WITH DAMP CLOTH.
- ⚠ WARNING: FAILURE TO FOLLOW THESE INSTRUCTIONS COULD RESULT IN SERIOUS INJURY OR DEATH. ADULT SET-UP AND SUPERVISION REQUIRED.

⚠ CAUTION: The blower is a high volume blower, and is capable of moving large volumes of air very quickly. Place the blower in an area where it will not suck in dirt or leaves. Keep away from water, pools, spas and traffic. Keep children away from the blower. Only the blower supplied should be used for inflation.

### INSTRUCTIONS FOR BLOWER INSTALLATION AND OPERATION

**NOTE:** Set up as close to power source as possible. The product should be periodically examined for potentially unsafe conditions such as: damaged cord, plug, housing or parts, and that in the event such damage is found, the product should not be used until properly repaired. If these checks are not carried out, the toy could overturn or otherwise become a hazard. Never leave the blower outside in the rain or elements when not in use. Thoroughly dry before use. When in use, do not place the cord across traffic areas, water or damp areas. The blower should be placed on a stable surface and anchored per product instructions.

- 1) Make sure that the blower switch is in the "OFF" position. Plug the blower into a properly grounded (110-120V GFCI outlet).
- 2) To disconnect, an adult only should grip the plug and pull from wall outlet.

⚠ **WARNING: FAILURE TO FOLLOW THESE INSTRUCTIONS COULD RESULT IN SERIOUS INJURY OR DEATH.**

ADULT SET-UP AND SUPERVISION REQUIRED.

- Use only with Ground Fault Circuit Interrupt (GFCI) receptacle.
- Do not use extension cords with this product.
- Outdoor use only.

### ⚠ WARNING

- Adult installation and supervision required.
- This blower is for residential use only (110-120V GFCI outlet). It is not intended to be used in commercial or industrial settings.
- Never insert fingers, pencils or any other object through the grille at ANY time.
- Do not operate any appliance with a damaged cord or plug, after the appliance malfunctions or has been dropped or damaged in any manner.
- Do not operate in the presence of explosive and/or flammable fumes.
- To reduce the risk of fire or electric shock, do not use this blower with any solid-state speed control device.

### INSTRUCTIONS FOR BLOWER CLEANING AND STORAGE

Do not immerse the blower in water. Unplug the blower before cleaning, wipe with a damp cloth. The blower does not require any lubrication and has no user serviceable parts. Do not attempt to service the blower. When not in use, store the blower indoors in a dry place. Store the blower upright on a stable surface. Loosely coil the cord and place it beside the blower.

### GROUNDING METHODS

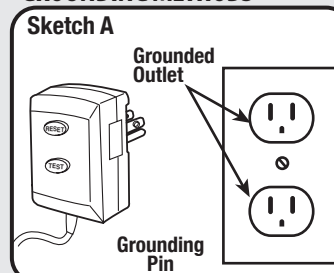

followed. This product is for use on a nominal 110-120-volt supply circuit, an has a grounding plug that looks like the plug illustrated in sketch A. Temporary adapters should not be used. Do not use product until a properly grounded outlet (sketch A) can be installed by a qualified electrician.

### USE ONLY ON GFCI PROTECTED RECEPTACLES GROUNDING INSTRUCTIONS FOR ALL GROUNDED, CORD-CONNECTED PRODUCTS

This product should be grounded. In the event of an electrical short circuit, grounding reduces the risk of electric shock by providing an escape wire for the electric current. This product is equipped with a cord having a grounding wire with an appropriate grounding plug. This plug must be plugged into an outlet that is properly installed and grounded in accordance with all local codes and ordinances. **DANGER** - Improper installation of the grounding plug can result in a risk of electric shock. If repair or replacement of the cord or plug is necessary, do not connect the grounding wire to either flat blade terminal. The wire with insulation having an outer surface that is green, with or without yellow stripes, is the grounding wire. Check with a qualified electrician or serviceman if the grounding instructions are not completely understood, or if in doubt as to whether the product is properly grounded. Do not modify the plug provided; if it will not fit the outlet, have the proper outlet installed by a qualified electrician. For a grounded, cord-connected product, rated less than 15 amperes and intended for use on a nominal 110-120-volt supply circuit, these instructions should be

This blower is not a toy. Use under the direct supervision of a competent adult. keep away from children. READ AND SAVE THESE INSTRUCTIONS

## ⚠ SAFETY WARNINGS: SET UP

**ADULT SET UP REQUIRED.** Falls onto hard surfaces could result in head or other serious injuries. Never install on concrete, asphalt, packed earth, wood or other hard surfaces.

- Intended for outdoor domestic family use only. Not for use in public areas or as a rental.
- Product is heavy. Use caution when lifting.
- Do not drag across concrete, pavement or other rough surfaces.
- **WARNING!** Keep away from fire. Keep fabric clear of all flame and ignition sources.
- Do not set up in windy or rainy conditions. Sudden gusts of wind may lift the product off of the ground.
- Product can be installed in any orientation in relation to the sun, since there are no metal components or surfaces that can absorb excessive solar radiation.
- Set-up in outdoor location only that meets the following criteria:
  - Place on level ground on grass or dirt surface to allow proper use of stakes. Placing on slanted or uneven surfaces may cause the product to tip.
  - Stakes need to be inclined at a certain angle for better anchorage. Stakes shall be placed level with or under the ground in order to reduce tripping hazards.
- Minimum clearance zones: Place at least 6.6 ft. (2m) away from limited to fences, buildings, trees, overhead branches, laundry lines, electrical wires, walls, or open bodies of water or sources of water.
- Make sure the area around the product is secure by adding safety barriers, if necessary, to keep young children and pets from gaining access.
- Install all attachments and ballasts supplied with this product.
- Do not use extension cords with this blower. Set up as close to power source as possible. Blower must be securely anchored to the ground before use.
- **CAUTION:** The blower is a high volume fan, and is capable of moving large volumes of air very quickly. Place the fan in an area where it will not draw in dirt or leaves. Keep fan and power cord away from children, water, pools, spas and traffic.
- **ATTENTION:** Blower must remain ON and continuously inflate bouncer during use. Airflow through seams is normal. Do not try to seal or repair seams. Only the blower supplied should be used for inflation. Do not allow children to play in the product until it is fully inflated.

## ⚠ SAFETY WARNINGS: USAGE

**ADULT SUPERVISION REQUIRED.**  
**NEVER LEAVE CHILDREN UNATTENDED.**



- Constant, competent adult supervision of children and other young users is required at all times.
- Keep the area around the product clean, and clear of objects, to prevent slips and falls.
- Instruct children on proper use of this product. Do not use in a manner other than intended.
  - Helmets, headgear, shoes, glasses, loose clothing, scarves, hoods, or clothing containing drawstrings should not be worn when using this product.
  - Do not allow other toys or objects inside the product.
  - Instruct children not to attach items to the product that are not specifically designed for use with the equipment, such as but not limited to, jump ropes, clothesline, pet leashes, cables and chains as they may cause a strangulation hazard.
- Keep pets away from product.
- Bounce away from others and stay away from sides wall, especially the opening.
- Do not jump onto or off of product.
- Do not allow children to play together who are unevenly matched in weight and height.
- Only one child at a time is allowed on each slide and climber.
- Children must not slide down head first on their stomach.
- Do not let children walk on the side where blower motor is attached.
- Always dry product before storage.
- Never use product as a flotation or life saving device.
- Always check product and all its anchorage points during use, and re-secure, as appropriate. Always check for excessive air loss, and re-inflate before allowing play to continue.
- As an outdoor product, this inflatable is subject to wear and deterioration. Keep product properly maintained and watch for signs of fabric failure. Weak or torn surfaces must be repaired promptly.
- If product contains a pool:
  - Never dive or jump into the pool area.
  - Do not sit on the edges of the pool as flooding may occur.
  - Always drain product after use. Do not leave it inflated or full of water overnight.
  - Keep the pool area clean to prevent illness. Instruct all children never to drink pool water and to practice good hygiene.

## Playing in the Water Park

**NOTE:** It is normal to see air bubbles rising from the pool floor and other wet areas of the Water Park.

### SLIDING

1. Climb up the climbing wall to the top of the slide.
2. Sit on the top with our feet pointing down the slide.
3. Scoot forward and slide down into the splashdown area.
4. **DO NOT** slide down on your stomach or head first.
5. Do not face the sun when sliding.

### ⚠ CAUTIONS:

- Children can drown in a very small amount of water. Empty the pool when not in use.
- To avoid the risk of injury, **ALWAYS** slide down the slide with feet first. **NEVER** slide down on your stomach or head first.
- Only one child should be on the slide and climb at one time.
- Total weight of children must not exceed 350 lbs. (max. individual weight = 110 lbs) on inflated surface.
- **NEVER** slide down the slide until the splashdown area is clear.
- **NEVER** slide or jump down the climbing wall.

## Water Signs in Water Park

### IMPORTANT:

To avoid injury and death, heed all warning signs that are printed on the Water Park. These signs are shown below:



### WARNING:

NEVER JUMP OR DIVE FROM ANY PART OF THE WATER PARK!

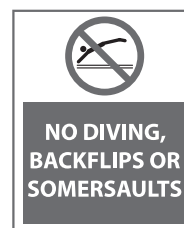

### WARNING:

ONLY SLIDE DOWN THE WATER SLIDE IN A SITTING POSITION WITH FEET IN FRONT OF YOU.



### WARNING:

DO NOT USE OUTDOOR FOOTWEAR ON ANY PART OF THE WATER PARK AS IT MAY BECOME DAMAGED.



### WARNING:

BE CAREFUL! SOME OF THE WATER PARK SURFACES ARE SLIPPERY AND MAY PRESENT A TRIPPING HAZARD.

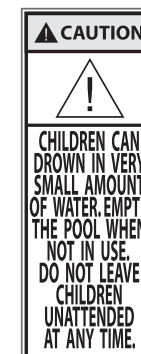

### WARNING:

CHILDREN CAN DROWN IN VERY SMALL AMOUNT OF WATER. EMPTY THE POOL WHEN NOT IN USE. DO NOT LEAVE CHILDREN UNATTENDED AT ANY TIME.

2

Once Water Park is inflated, attach the Water Anchor Bag to the plastic connectors at the base of the Water Park.

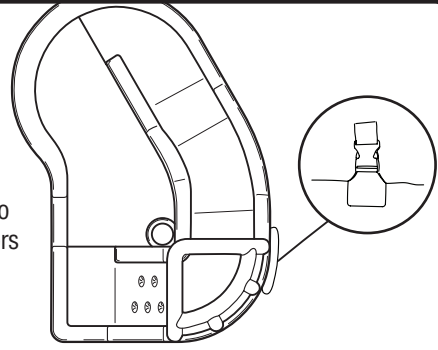

3

Once attached, fill the Anchor Bag with water until it is completely full.

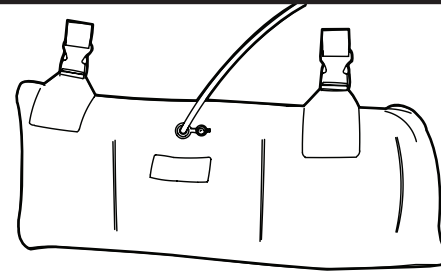

**NOTE:** The Water Anchor Bag needs to be attached to the Water Park whether or not the Water Sprayer is used. The Water Anchor Bag prevents the Water Park from toppling over when people climb on it.

## Staking the Water Park

**CAUTIONS:** The Water Park and all its anchorage points should be checked before and during use. Reinflate or re-secure as appropriate. DO NOT let children play on the water park until it is fully inflated!

1

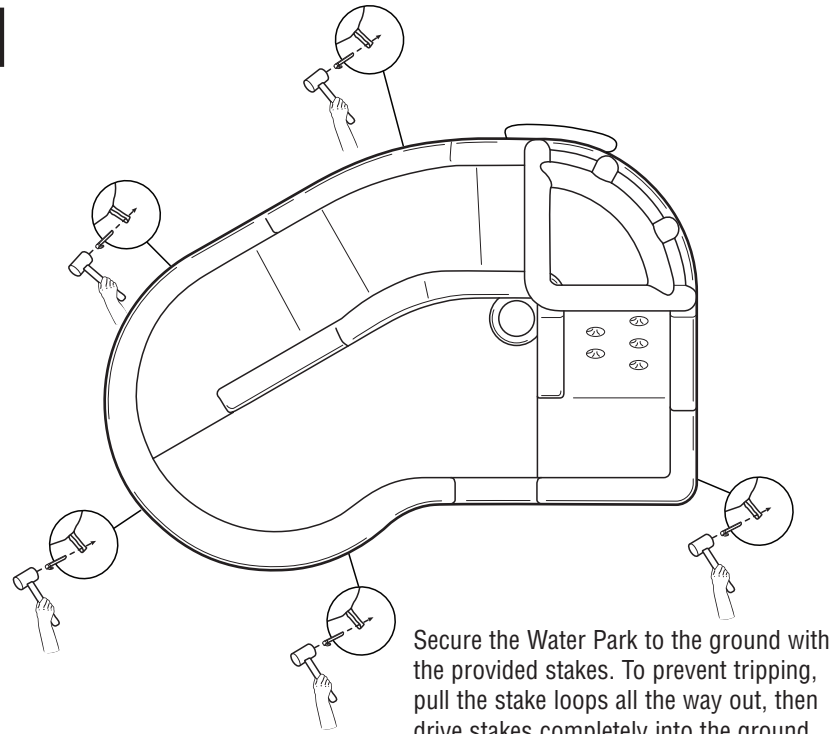

Secure the Water Park to the ground with the provided stakes. To prevent tripping, pull the stake loops all the way out, then drive stakes completely into the ground.

2

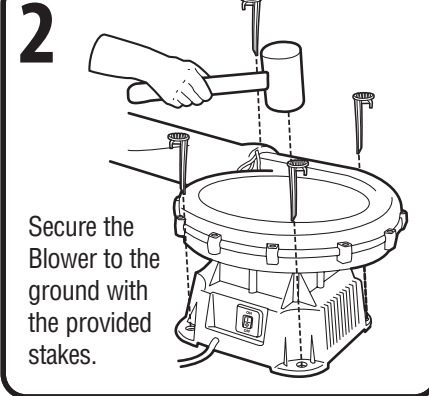

Secure the Blower to the ground with the provided stakes.

### WATER PARK CAUTIONS:

- Drive ground stakes completely into the ground to avoid tripping hazard.
- Do not use the Water slide until an Adult has assembled, staked down, and fully inflated.
- Do not set up or inflate the Water Park in windy and/or rainy conditions as wind gusts may cause the park to become unstable and possibly be lifted from the ground.

## Water Park Spray Assembly, Part 2

1

Turn on the garden hose and adjust the pressure as desired. Make sure that a steady spray of water comes out of the sprayer and keep the slides wet.

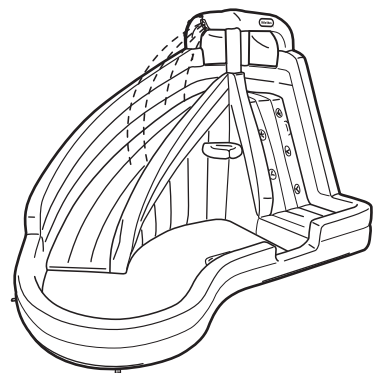

7

## Water Park Placement

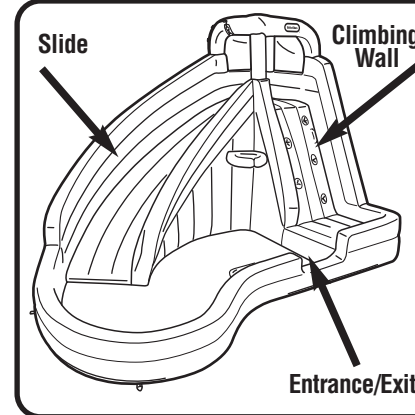

Designate a flat, level surface that allows for 6.6 feet (2m) of minimum clearance around the Water Park.

**NOTE:** DO NOT place the Water Park on a hard surface like asphalt, concrete or packed earth as both serious bodily injury and damage to the Water Park could result.

### ASSEMBLY AREAS

- Make sure the assembly area is flat and level and is free of rocks, sharp objects or other obstructions.
- Do not set up the Water Park on a slope or inline.
- Do not set up the Water Park on hard-packed earth, asphalt, decking or any hard surface as doing so may result in physical injury and/or damage to the Water Park.
- Once the Water Park is inflated or filled with water, do not attempt to drag it to another location.
- Check your local county or city regulations for requirements on securing the pool.
- Secure the pool from unauthorized use.

## Minimum Clearance Zones

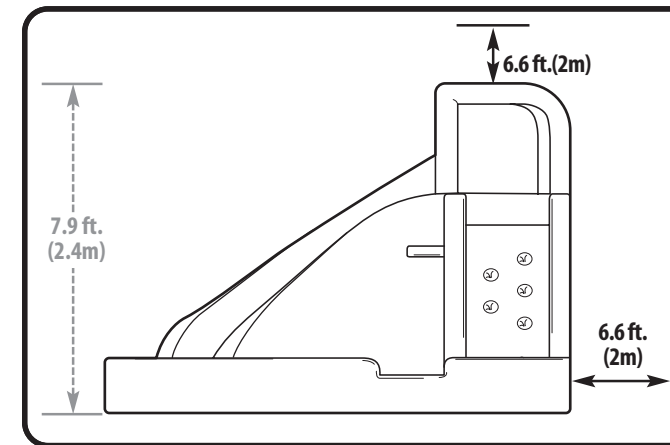

### MINIMUM CLEARANCE ZONES

Make sure that there is a 6.6 ft. (2m) obstacle-free zone around the product, including the slide and overhead.

**INFLATABLE SIZE:** 12.9 x 9.8 x 7.9 ft. (3.9 x 2.9 x 2.4m)

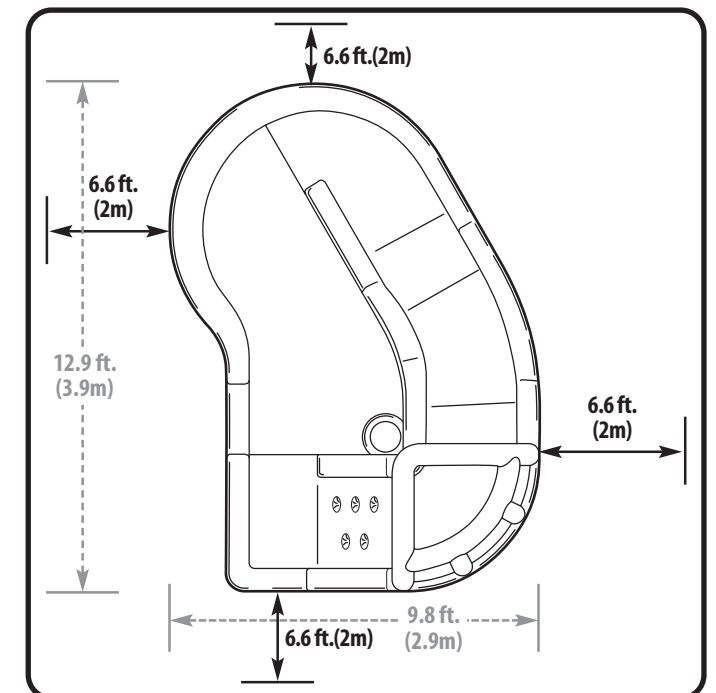

## Unfolding the Water Park

1

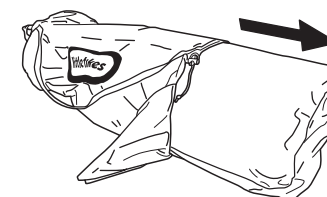

Remove contents from the carrying bag.

2

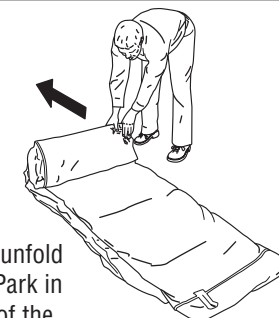

Unroll and unfold the Water Park in the center of the designated area.

3

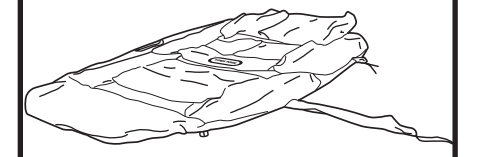

4

## Blower Set Up

1

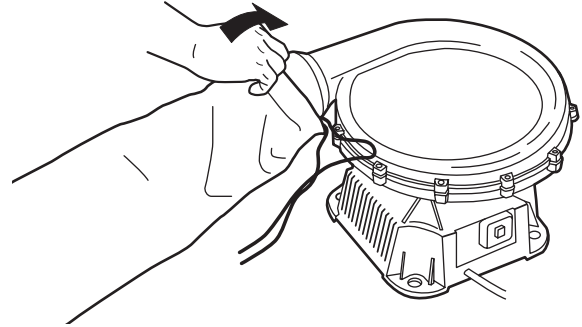

Attach long Air Intake Tube on the Water Park to the mouth of the Blower Motor with the attached drawstring. Make sure the Intake Tube is free of twists or kinks.

2

Wrap drawstring once around the Intake Tube before tying off. This ensures a tight seal.

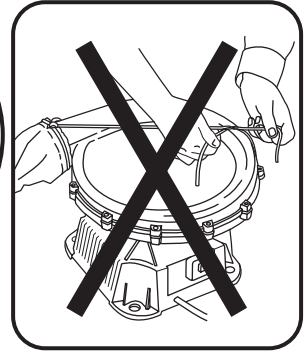
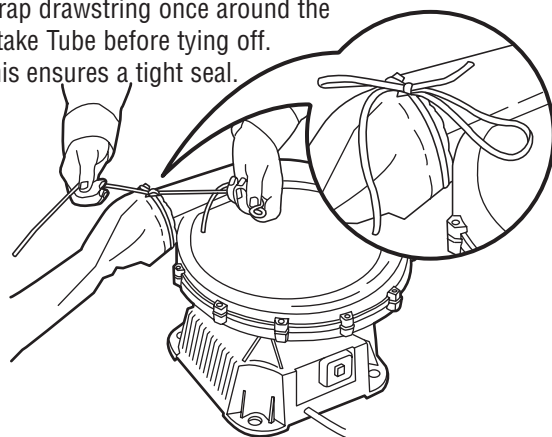

3

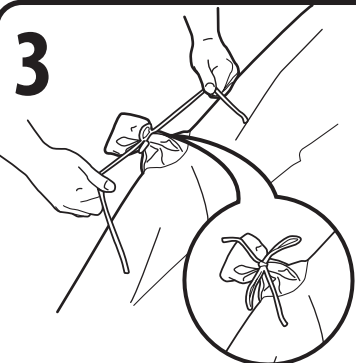

Tie off the short Air Outlet Tube tightly to make a good seal.

**NOTE:** Position the blower motor perpendicular and level to the Water Park. Make sure that the blower is upright on a stable surface. Do not place the blower in an area where it can draw up dirt, leaves and other debris. Make sure that the blower is at least 6.6 ft. (2m) away from any structure or obstacle such as a fence, garage, overhanging branches or electrical wires.

### ⚠ BLOWER CAUTIONS

- Do not open or try to service the blower. If blower needs servicing, take it to a reputable dealer.
- Clearly mark the path of the power cord to avoid tripping and/or damage by yard equipment such as lawn mowers, etc.
- Do not leave the blower unattended.
- Do not allow blower to be used or played with by children.
- Do not cover the air intakes when the blower is being used and do not insert small objects into any part of the blower.
- **WARNING:** Electrocutation Hazard - DO NOT USE EXTENSION CORDS WITH THIS PRODUCT.
- Disconnect the blower from the power source and Water Slide when moving the slide.
- **WARNING:** To reduce the risk of fire or electric shock, do not use this blower with any solid - state speed control device.
- The blower should be securely staked to the ground before use.

### BLOWER MAINTENANCE

- Blower must be unplugged before servicing.
- Product should be periodically examined for potentially unsafe conditions such as damaged cord, plug, housing, or parts, and that in the even such damage is found, the product should not be used until properly repaired.
- The blower does not require any lubrication and has no user serviceable parts. Do not attempt to service the blower.
- Do not immerse the blower in water. To clean, wipe with a damp cloth.
- Regularly inspect the intake and output openings and keep free of dirt, leaves, etc.
- When not in use, store the blower indoors in a dry place.
- Store the blower upright on a stable surface.
- Loosely coil the cord and place it beside the blower.
- When in use, do not place the cord across traffic areas, water or damp areas.
- The blower is a high volume blower, capable of moving large volumes of air very quickly. Place the blower in an area where it will not draw in dirt or leaves.

5

## Inflating the Water Park

4

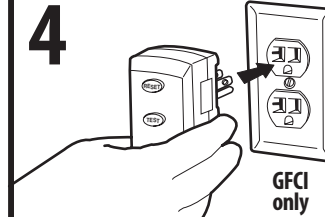

Test the Blower AC Adapter:  
1. Plug GFCI into receptacle.  
2. Press reset button.  
3. Press test button.  
4. Press reset button to us product. Do not use if the button fails to disable the blower.

**⚠ WARNING: ⚠**

If the blower remains ON when the "test" button is pushed, the unit is NOT working properly. DO NOT USE THE UNIT. Take the unit to a certified electrician immediately.

5

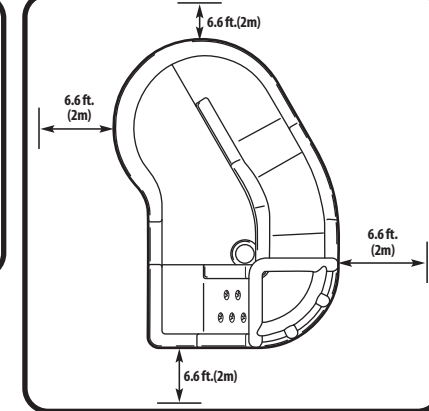
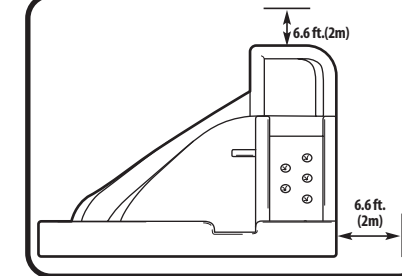

Re-measure minimum clearance zone prior to inflation.

6

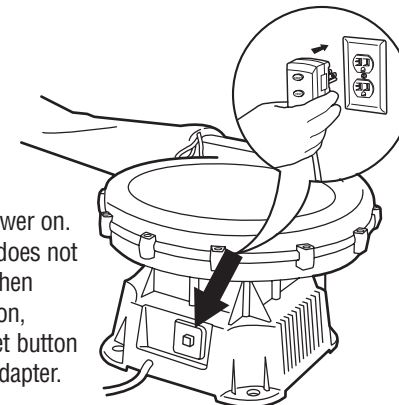

Switch power on. If blower does not operate when switched on, press reset button on GFCI adapter.

7

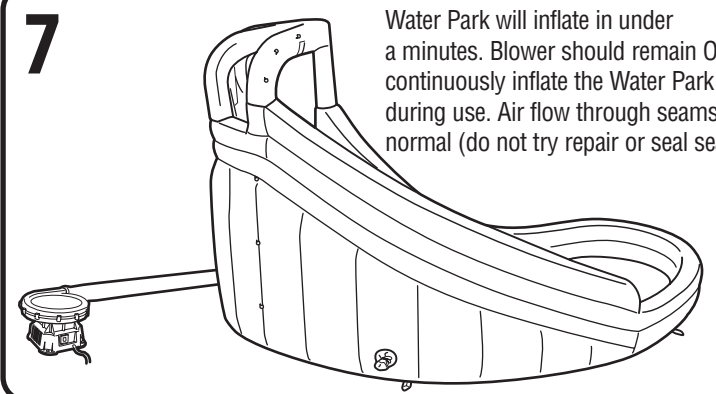

Water Park will inflate in under a minutes. Blower should remain ON to continuously inflate the Water Park during use. Air flow through seams is normal (do not try repair or seal seams).

## Water Park Spray Assembly, Part 1

1

Make sure the Hose Assembly is attached to the Water Park as shown. Connect the Tubing to the hook and loop closures down the side of the inflatable.

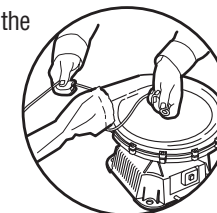

Connect the Single - Outlet Sprayer to the top as shown

Attach the garden hose to the end of the Tubing Assembly.

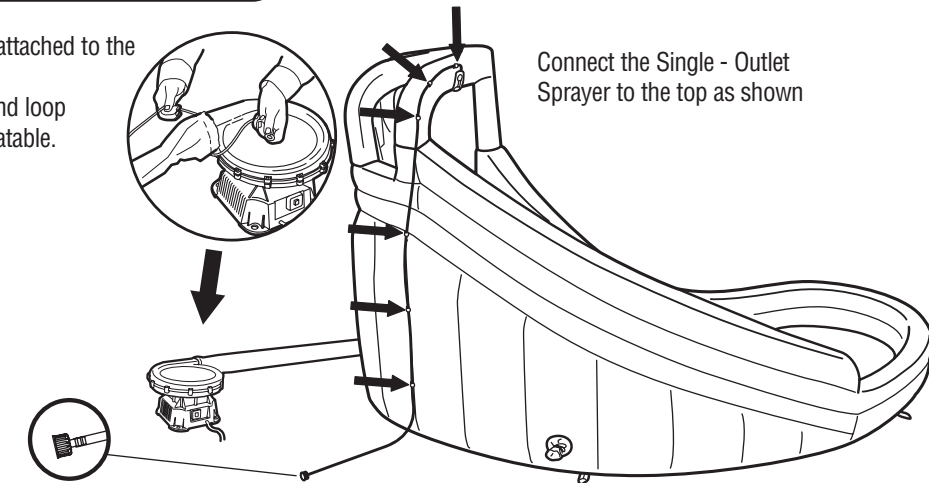

6