

SERVICING OF A DOUBLE-INSULATED PRODUCT:

In a double-insulated product, two systems of insulation are provided instead of grounding. No grounding means is provided on a double-insulated product, nor should a means for grounding be added to the product. Servicing of a double-insulated product requires extreme care and knowledge of the system, and should be done only by qualified service personnel. Replacement parts for a double-insulated product must be identical to those parts in the product. A double-insulated product is marked with the words "DOUBLE INSULATION" or "DOUBLE INSULATED." The symbol  may also be marked on the product.

DOUBLE INSULATION

LIMITED WARRANTY

The Little Tikes Company makes fun, high quality toys. We warrant to the original purchaser that this product is free of defects in materials or workmanship for 90 days from the date of purchase (dated sales receipt is required for proof of purchase). At the sole election of The Little Tikes Company, the only remedies available under this warranty will be either replacement of the defective part or replacement of the product. This warranty is valid only if the product has been assembled and maintained per the instructions. This warranty does not cover abuse, accident, cosmetic issues such as fading or scratches from normal wear, or any other cause not arising from defects in material and workmanship.

U.S.A. and Canada: For warranty service or replacement part information, please visit our website at www.littletikes.com, call 1-800-321-0183 or write to: Consumer Service, The Little Tikes Company, 2180 Barlow Road, Hudson OH 44236, U.S.A. Some replacement parts may be available for purchase after warranty expires - contact us for detail.

Outside U.S.A. and Canada: Contact place of purchase for warranty service.

Indoor Bouncers Warranty: We warrant to the original purchaser that the material in this product is free of defects in materials or workmanship for 90 days from the date of purchase, (dated sales receipt is required for proof of purchase). This warranty gives you specific legal rights, and you may also have other rights, which vary from state/country to state/country. Some states/countries do not allow the exclusion or limitation of incidental or consequential damages, so the above limitation or exclusion may not apply to you.

*The warranty period is three months for daycare or commercial purchasers.



Princess Bouncer™

641824

AGES 2-6 YEARS
ADULT ASSEMBLY AND SUPERVISION REQUIRED.

CONTENTS

- A. (1) Princess Bouncer™
- B. (2) Repair Patches

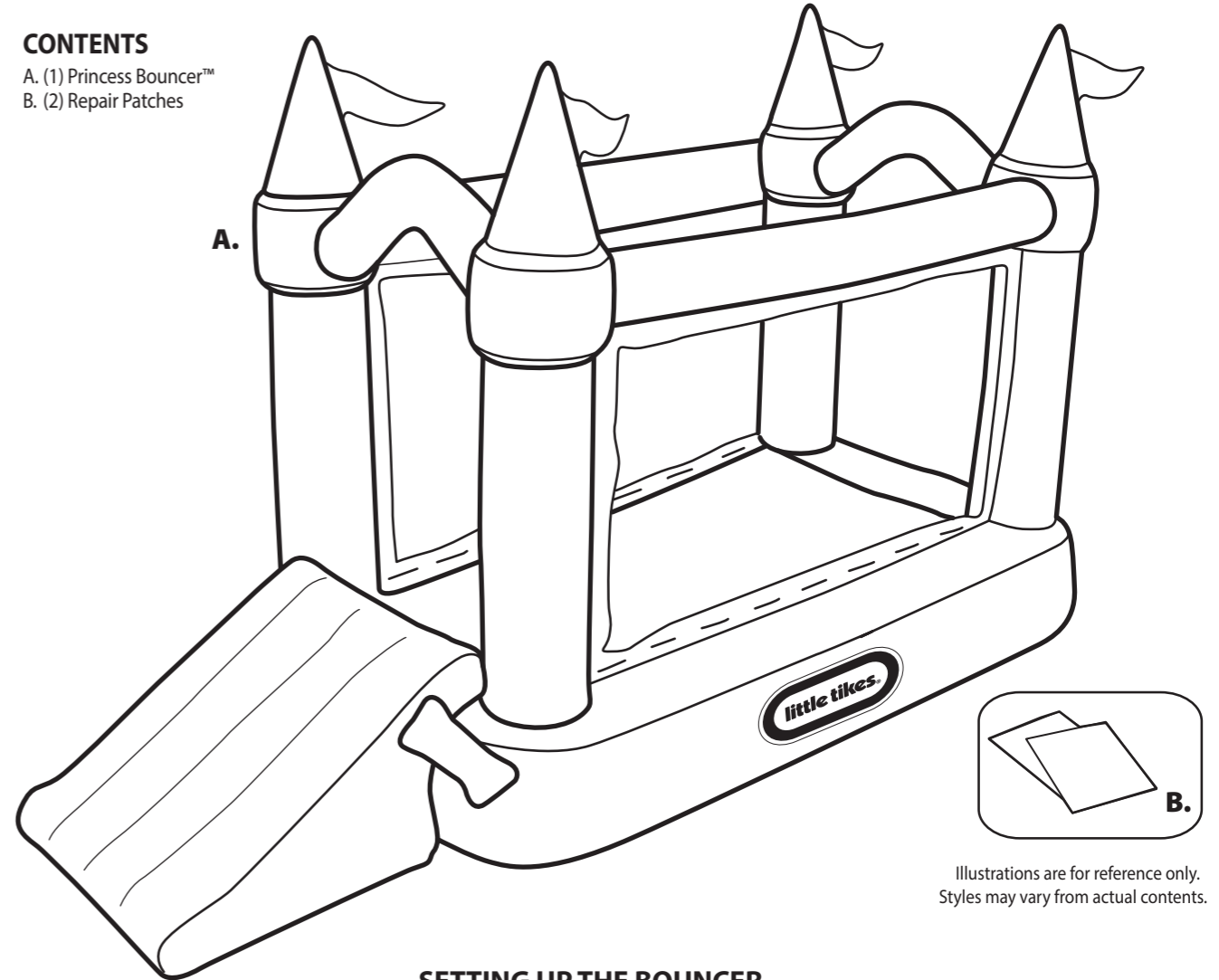

Illustrations are for reference only.
Styles may vary from actual contents.

SETTING UP THE BOUNCER

An adult must set up and inflate the unit. Here's how:

1. Clear an indoor area (see diagrams below) and place the folded Princess Bouncer™ inside the area.
2. Fully unfold the Princess Bouncer™ with the control panel near a 120 volt AC wall electrical outlet.

MINIMUM CLEARANCE ZONES: Make sure that there is 6.6 ft. (2 m) obstacle-free zone around the product.

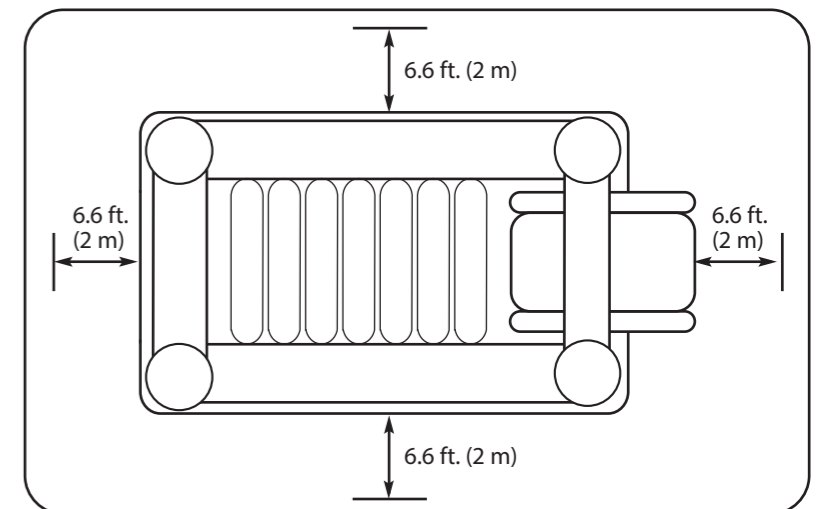
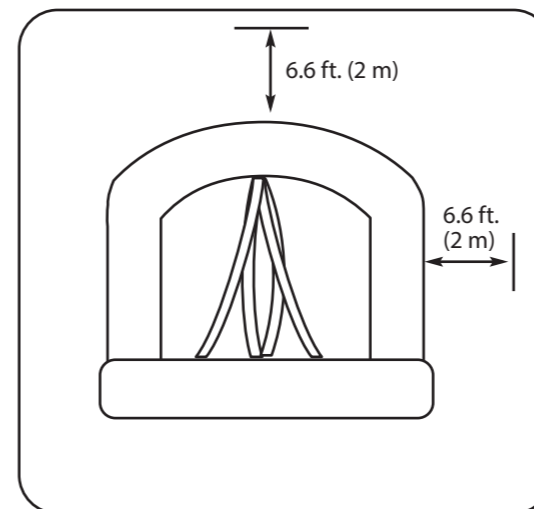

 'Let's care for the environment!'
The wheeie bin symbol indicates that the product must not be disposed of with other household waste. Please use designated collection points or recycling facilities when disposing of the item. Do not treat old batteries as household waste. Take them to a designated recycling facility.

Please keep this manual as it contains important information.



© The Little Tikes Company, an MGA Entertainment company. LITTLE TIKES® is a trademark of Little Tikes in the U.S. and other countries. All logos, names, characters, likenesses, images, slogans, and packaging appearance are the property of Little Tikes.
Little Tikes Consumer Service
2180 Barlow Road Hudson, Ohio 44236 U.S.A.
1-800-321-0183
Printed in China

MGA Entertainment UK Ltd
50 Presley Way
Crownhill
Milton Keynes
MK8 0ES
Bucks, UK
0800 521 558

www.littletikes.com
www.littletikes.co.uk



INFLATING THE BOUNCER

- Check that the buckles on the slide are properly adjusted. If necessary, twist the connector to tighten. (Fig 1)

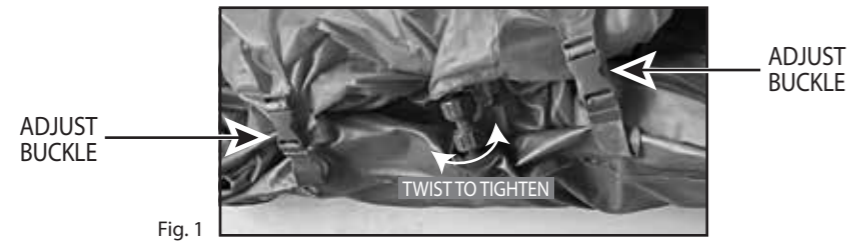

Fig. 1

- With the ON/OFF switch in the OFF (0) position, and the INFLATE/RESET/DEFLATE knob in the RESET position, open the cord storage area door and carefully extend the cord. (Fig. 2)
- Plug the cord into the wall outlet.
- Turn the ON/OFF switch to ON and rotate the INFLATE/DEFLATE knob to INFLATE. (Fig. 2)
- Allow the Bouncer to inflate until it is firm but the seams still show slight wrinkling then turn the knob to RESET and turn the ON/OFF switch to OFF. (DO NOT over-inflate.)
NOTE: The knob must be completely centered at RESET to prevent deflation. (Fig. 2A)
- Place the power cord in the control panel cord storage door prior to allowing children to play on the unit.

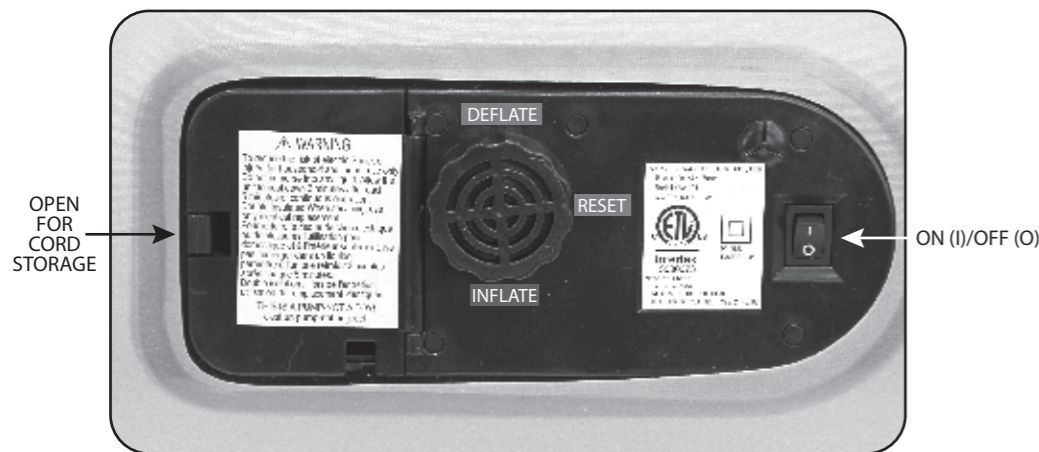

Fig. 2



Fig. 2A

DEFLATING THE BOUNCER

To deflate the bouncer:

- Open the large air outlet near the control panel. (Fig 3)
- Turn the knob on the control panel to DEFLATE and the ON/OFF switch to ON.
- Once deflated, turn the ON/OFF switch to OFF. Unplug the unit and store the cord inside the control panel door. (Fig. 4)

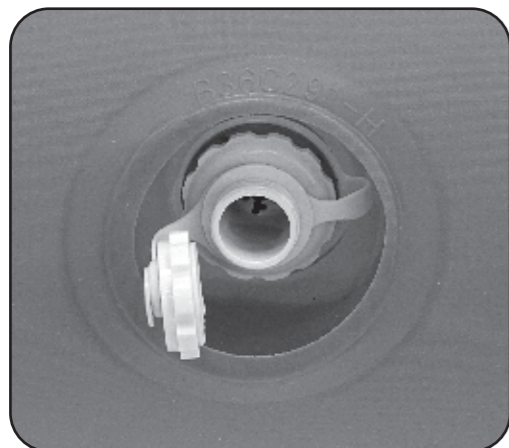

Fig. 3

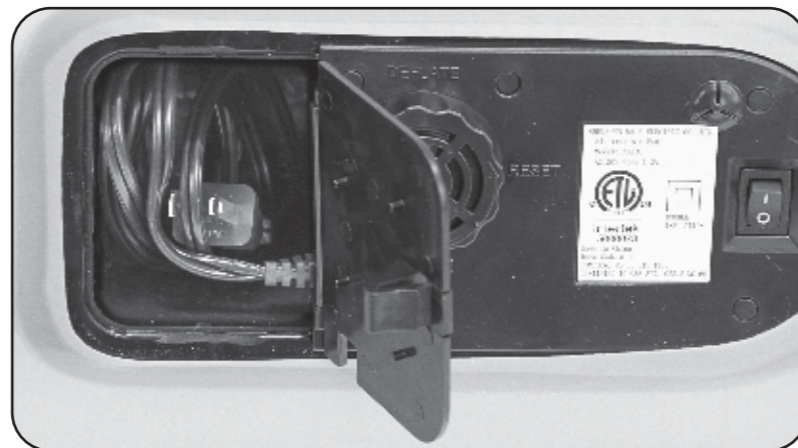

Fig. 4

REPAIRING A PUNCTURE

In the event the bouncer is accidentally punctured, an adult must perform the following steps:

- Deflate the item, clean the punctured area with water and allow it to dry.
- Cut a portion of the patch allowing approximately 1 1/2 inches of excess patch material on all sides of the opening to be patched and round the corners.
- Remove the backing from the patch material, position the patch over the damaged area and smooth out any bubbles with a paper towel.
- Allow the item to sit for 30 minutes before re-inflating.

MAINTENANCE

The product should be periodically examined for potentially unsafe conditions such as: damaged cord, plug, housing, etc. In the event such damage is found, the product should not be used until properly repaired. Refer to the instructions for set-up, storage, maintenance and care. To clean use mild detergent and water.

⚠ WARNING:

ADULT SUPERVISION AND SET UP REQUIRED. This product should be inflated or deflated by a competent adult.

- Not for outdoor use. Sudden gusts of wind can lift the product off the ground.
- Minimum clearance zones of 6.6 ft. (2 m) in any direction are required.
- Keep the area around the product clean and clear of objects to prevent slips and falls.
- DO NOT allow attachment of items such as jump ropes, pet leashes, cables, etc., to product as they may cause a strangulation hazard.
- DO NOT drag the unit as doing so may cause irreparable damage.
- Ensure the play area is free from hazards such as furniture, walls, sharp objects and other hard surfaces before inflating the unit and playing in it.
- DO NOT leave children unattended at any time.
- DO NOT use the unit if it is wet as it may become slippery.
- DO NOT allow children to play in the product until it is fully inflated.
- Children must remove helmets, loose clothing, scarves, headgear, shoes and glasses, as well as any sharp objects from their pockets, as they may puncture the bouncing surface.
- Toys and other objects should never be allowed inside the bouncer.
- Keep pets away from the product.
- Children should bounce away from others and stay away from openings and side walls.
- DO NOT allow food, drink or gum inside unit.
- Maximum user weight is 60 lbs. (27 kg). Total weight of children must not exceed 120 lbs. (54 kg).
- No more than 2 children should play on the bouncer at the same time.
- DO NOT use extension cords with this product.
- THIS IS NOT A FLOTATION DEVICE. DO NOT USE IN OR NEAR WATER.
- DO NOT allow children to play together who are unevenly matched in weight and height.
- Prior to deflating, remove all children.
- Always deflate product after use, and store indoors.
- Users must be discouraged from attempting any unauthorized modification.
- Remove the plug from the socket before use.

IMPORTANT PUMP INFORMATION

The pump is not serviceable. Do not attempt to service the pump. Doing so may cause the warranty to be voided.

- To reduce the risk of electric shock, use indoors only.
- Remove the bouncer plug from the electrical outlet before cleaning.
- Allow the unit to cool down for 3 minutes after 5 minutes of continuous pump operation.
- The pump contains a thermal switch that will automatically shut down the unit if it gets too hot. To reset, turn the pump switch to OFF and unplug the unit from the AC outlet to allow it to cool. The pump will function properly once normal temperatures are reached.

⚠ WARNING:

- Do not use the electric pump near wet surfaces or if water has entered the pump.
- Do not immerse the bouncer pump in water or cleaning liquid.
- Always keep the power cord away from hot surfaces. If the power cord or plug is damaged, contact consumer service.
- This appliance has a polarized plug (one blade is wider than the other). This plug will fit in a polarized outlet only one way. If the plug does not fit fully in the outlet, reverse the plug. Do not change the plug in any way.
- Do not place the power cord under the bed, furniture or carpet coverings.